

Installation and Operating Instructions

Lumistar Luminaire USL 35, Stainless Steel

• **Important note:**

Sight glass luminaires are specifically and solely designed for mounting on top or side of sight glass units. Never use a luminaire in place of cover flange or complete sight glass unit to provide a closure for an opening in a process vessel. Luminaires which are to be used in Ex areas may only be installed and serviced by personnel duly qualified and authorised to do so.

• **Operating conditions – general:**

- Independent of vessel internal pressure/vacuum.
- Max. permissible ambient temperature at cable entry gland 90°C.
- 50 W and 100 W powered versions of the luminaires may only be used with non maintained push button switches.
- **Warning!** When the luminaire – whether fitted with existing or higher wattage lamp – is used in continuous ON mode, check the temperature of the luminaire, its lens glass and the light/sight glass fitting; these temperature values must not be allowed to exceed those stated in the relevant data sheet and/or separate sheet entitled "Installation and operating instructions".
If these values become critical, insert a momentary push button or time delay switch in the power supply to the luminaire to prevent overheating.

• **Electrical data – general:**

- Voltage, power and protection are shown on identity plate
- **Caution:** Excessive voltage will shorten lamp life

• **Installation - mechanical:**

The Lumistar luminaire USL 35 fits sight glasses as following: The luminaire fits over and is secured to a special circular male spigot or upstand on the cover flange of the sight glass. An O ring provides the seal to the sight glass.

A popular alternative is to mount the unit by means of an adapted clamp joint to DIN 32676/ISO 2852 standard. The tapered mating flange to the nozzle clamp flange comprises a specially machined ring with a sight glass fused concentrically into the metal and an upstand with O ring groove on its outer surface. The extended and reinforced lip of the luminaire USL 35 forms a sleeve which fits over the upstand, the O ring providing the seal to the clamp flange. Tightening the clamp then provides the closing pressure, sealing the fused metal-glass flange to the nozzle.

• **Servicing:**

- Keep luminaire clean
- Allow for mean lamp life
- Use only original replacement parts

• **Electrical connection:**

- Connecting cable (3 m) comes ready connected to the luminaire via cable entry gland.
- The unit is internally wired ready for operation.

• **Lamp exchange:**

- Caution: check body temperature before opening
- Switch of power to luminaire
- Loosen both screws in luminaire back plate
- Lift off back plate complete with attached lampsocket and defective lamp
- Pull out defective lamp
- Gripping new lamp with its protective material, insert carefully into 2 pin or Ba 15d socket and push in firmly
- Refit back plate complete with new lamp in socket, checking location of cabling and tighten securing crews.
- Switch on power
- **Caution:** only use lamps of identical type and power

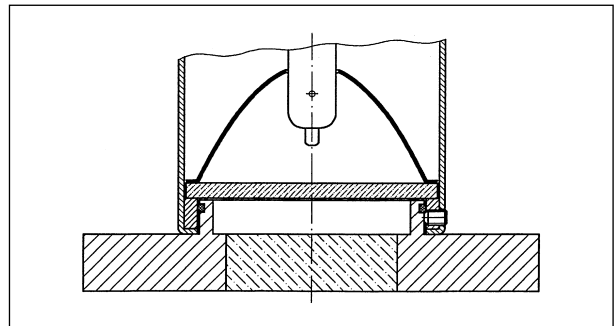

• **Replacement parts and ordering information:**

	Halogen filament lamp	
Socket	Nominal Voltage/Power	Part No.
GY 6.35	24 V/50 W	3232.242.00
Ba 15d	120 V/50 W	3232.275.00
GY 6.35	24 V/100 W	3232.244.00
Ba 15d	120 V/100 W	3232.272.00

Component	Part No.
Push button	6412.016.00
Dust cap for push button	2330.014.00
Reflector	5904.058.00
Gasket 70,5 x 1,5 mm 80 Shore, Viton (backplate to body)	0853.010.00
Lamp socket Ba 15d	1202.013.00
Lamp socket 2-Stift G 6.35	1202.025.00