

Installation and Operating Instructions



0093.142.00

Lumistar Luminaires USL 13-LED and USL 33-LED

Important, please note:

Sight glass luminaires are purpose-designed and intended solely for mounting on the top or side of sight glass units. Under no circumstances should a luminaire be used to replace a cover flange or complete sight glass fitting nor as a closure for an opening in a process vessel. Luminaires must be mounted, installed and serviced by staff who have the relevant qualifications and have been trained and authorised to do such work.

Caution:

Do not look into light – danger of impaired eyesight!

Electrical data, general:

- The voltage, output and protection type are shown on the name plate.
- Excess voltage will cause premature lamp failure.

General operating conditions:

- Independent of internal vessel pressure/vacuum
- Max. admissible ambient temperature at cable entry gland: 40°C
- The lights are designed for continuous operation. But they can also be delivered with a pushbutton.

Installation – mechanical:

The Lumistar luminaires USL 13-LED fit the following nominal sizes using the appropriate fastenings in each case:

Type of fitting	from DN	Hinged bracket	Flanged adapter
Sight glass unit similar to DIN 28120 or DIN 28121	50	+	-
Flow indicator	50	+	-
Screwed sight glass unit similar to DIN 11851	50/65	-	+
	80	+	-
	100	+	-
	125	+	-

Mounting with hinged bracket:

The hinged bracket can be used to fasten the luminaire to the cover flange of a circular sight glass fitting (or flow indicator) or to the slotted cover nut of a screwed sight glass similar to DIN 11851. The bracket is fixed in place in a blind hole tapped on the bolt pitch circle of the cover flange face, using the M6 screw provided. Alternatively, the bracket can be welded on.

Mounting with flange adapter:

The adapter is mounted between the glass disc and the slotted cover nut (DIN 11851). To do this, place an appropriate gasket between the glass disc and the adapter. Plug in the luminaire and tighten the grub screws located around the edge. The adapter is to be ordered separately.

The Lumistar luminaire USL 33-LED fits on the sight glass unit using the appropriate mounting attachment, as follows:

The luminaire is mounted over a special circular collar or connecting piece on the cover flange and secured in place. An O-ring is inserted as a seal for the sight glass. A tried-and-tested alternative is to mount the luminaire using an adapted clamped similar to DIN 32676/ISO 2852. The tapered mating flange to the nozzle clamp flange forms a special ring construction with a concentric sight glass fused into the metal and an upstand with a groove for the O-ring on the outer surface.



Lumistar luminaire USL 13-LED with hinged bracket

The extended, reinforced lip of the USL 33-LED luminaire forms a sleeve which fits over the collar, with the O-ring providing the seal to the clamp flange.

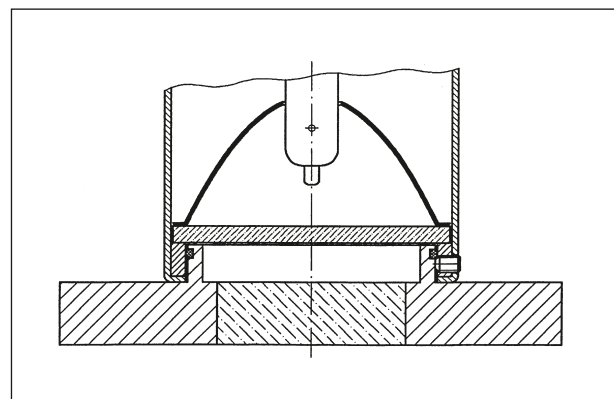

Lumistar luminaire USL 33-LED on Metaglas

• **Electrical connection:**

- The connecting cable (3 m) comes ready connected to the luminaire via the cable entry gland.
- The unit is internally wired and ready for operation.

• **Changing the illuminant:**

- Switch off power to the luminaire.
- Loosen both screws in the back plate of the luminaire.
- Lift off the back plate complete with the attached lamp socket and the illuminant to be replaced.
- Pull off the defective illuminant.
- Holding the new illuminant carefully insert it into the 2-pin socket and push it firmly into place.
- Refit the back plate complete with the new illuminant in its socket, paying attention to the correct positioning of the cables. Tighten the screws to fix in place.
- Switch on power.

• **Caution:**

- Only use lamps of the same type and with the same wattage!

• **Maintenance:**

- Keep the luminaire clean and free of dust.
- Please use original replacement parts only.
- Note the nameplate for power supply and wattage.

• **Replacement parts and ordering information:**

LED-illuminant		
Socket	Voltage/ power	Part. no.
GU4	12 V/2 W	3232.026.00

Component	Part. No.
Hinged bracket mounting	0354.024.00
Flange adapter mounting DN50 – USL 13, Ø 62 mm	1356.027.00
Flange adapter mounting DN65 – USL 13, Ø 65 mm	1356.030.00
Protective cap for push button	2330.013.00
Lid seal (between back plate and body)	0853.009.00
Lamp socket GU4	1202.023.00